

SECTION B-B

Rev.:	Date:	Name:	Description:
B	02-02-2016	IKR	Handle name change
A	03-11-2015	IKR	Initial release

Part name: TRAIL	Projection: 	Sheet format: A3	Tolerance unless otherwise specified DS/ISO 2768-1M																		
Customer:	Drawn by: IKR date 03-11-2015	Scale: 1:1																			
Part no.: 538760128	Page 1 of 2	<table border="1"> <thead> <tr> <th>Linear dimensions:</th> <th>0-3</th> <th>3-6</th> <th>6-30</th> <th>30-120</th> <th>120-400</th> <th>400-1000</th> <th>1000-2000</th> <th>2000-4000</th> </tr> </thead> <tbody> <tr> <td></td> <td>± 0.1</td> <td>± 0.1</td> <td>± 0.2</td> <td>± 0.3</td> <td>± 0.5</td> <td>± 0.8</td> <td>± 1.2</td> <td>± 2</td> </tr> </tbody> </table>		Linear dimensions:	0-3	3-6	6-30	30-120	120-400	400-1000	1000-2000	2000-4000		± 0.1	± 0.1	± 0.2	± 0.3	± 0.5	± 0.8	± 1.2	± 2
Linear dimensions:	0-3	3-6	6-30	30-120	120-400	400-1000	1000-2000	2000-4000													
	± 0.1	± 0.1	± 0.2	± 0.3	± 0.5	± 0.8	± 1.2	± 2													
Material: Zinc	Weight: 164.10 grams	<table border="1"> <thead> <tr> <th>Angle</th> <th>Radius</th> </tr> </thead> <tbody> <tr> <td>± 0.5°</td> <td>± 0.2</td> </tr> </tbody> </table>		Angle	Radius	± 0.5°	± 0.2														
Angle	Radius																				
± 0.5°	± 0.2																				
<p>furnipart®</p> <p>Delta 2 DK-8382 Hinnerup Phone: +45 87 64 35 00 Fax: +45 87 64 35 01</p>		<p>Copyright: THIS DRAWING MAY NOT BE COPIED OR REPRODUCED IN ANY WAY WITHOUT DIRECT PERMISSION FROM FURNIPART A/S</p>																			

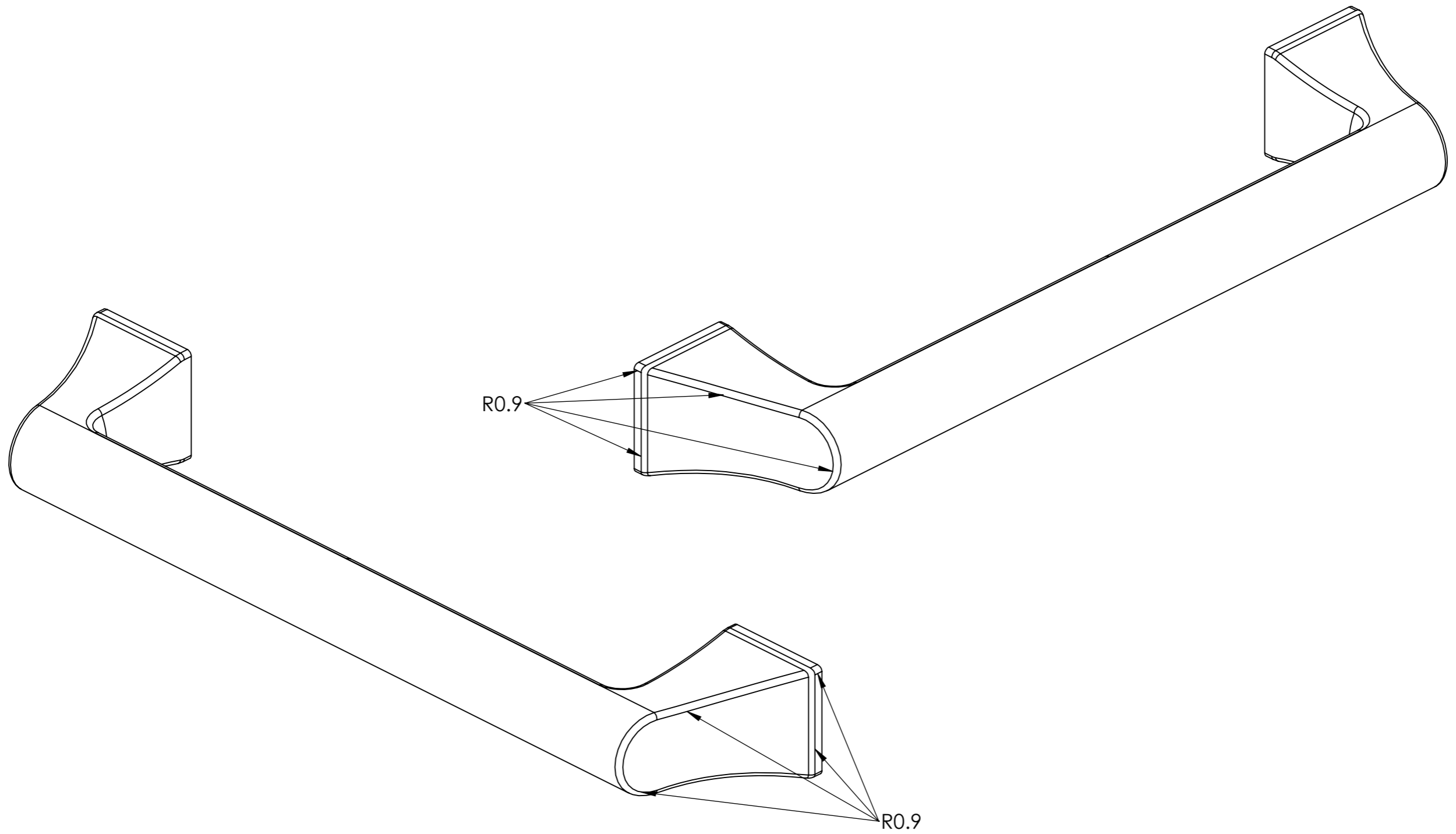

Rev.:	Date:	Name:	Description:
B	02-02-2016	IKR	Handle name change
A	03-11-2015	IKR	Initial release

Part name: TRAIL	Projection: 	Sheet format: A3	Tolerance unless otherwise specified DS/ISO 2768-1M																		
Customer:	Drawn by: IKR date 03-11-2015	Scale: 1.5:1																			
Part no.: 538760128	Page 2 of 2	<table border="1"> <thead> <tr> <th>Linear dimensions:</th> <th>0-3</th> <th>3-6</th> <th>6 - 30</th> <th>30- 120</th> <th>120- 400</th> <th>400- 1000</th> <th>1000- 2000</th> <th>2000 - 4000</th> </tr> </thead> <tbody> <tr> <td></td> <td>± 0.1</td> <td>± 0.1</td> <td>± 0.2</td> <td>± 0.3</td> <td>± 0.5</td> <td>± 0.8</td> <td>± 1.2</td> <td>± 2</td> </tr> </tbody> </table>		Linear dimensions:	0-3	3-6	6 - 30	30- 120	120- 400	400- 1000	1000- 2000	2000 - 4000		± 0.1	± 0.1	± 0.2	± 0.3	± 0.5	± 0.8	± 1.2	± 2
Linear dimensions:	0-3	3-6	6 - 30	30- 120	120- 400	400- 1000	1000- 2000	2000 - 4000													
	± 0.1	± 0.1	± 0.2	± 0.3	± 0.5	± 0.8	± 1.2	± 2													
Material: Zinc	Weight: 164.10 grams	<table border="1"> <thead> <tr> <th>Angle</th> <th>Radius</th> </tr> </thead> <tbody> <tr> <td>± 0.5°</td> <td>± 0.2</td> </tr> </tbody> </table>		Angle	Radius	± 0.5°	± 0.2														
Angle	Radius																				
± 0.5°	± 0.2																				
<table border="1"> <tr> <td colspan="2" style="text-align: center;">furnipart®</td> </tr> <tr> <td>Delta 2 DK-8382 Hinnerup</td> <td>Phone: +45 87 64 35 00 Fax: +45 87 64 35 01</td> </tr> </table>		furnipart®		Delta 2 DK-8382 Hinnerup	Phone: +45 87 64 35 00 Fax: +45 87 64 35 01	<p style="text-align: center;">COPYRIGHT: THIS DRAWING MAY NOT BE COPIED OR REPRODUCED IN ANY WAY WITHOUT DIRECT PERMISSION FROM FURNIPART A/S</p>															
furnipart®																					
Delta 2 DK-8382 Hinnerup	Phone: +45 87 64 35 00 Fax: +45 87 64 35 01																				